



DELTA

**VRF One-way Cassette Indoor Units
80CO SERIES**

INSTRUCTION MANUAL

WARNING!

Read and follow all safety precautions in Instruction Manual - improper use can cause serious injury.

USER NOTICES

- ☆ When operating, the total capacity of the cooperating indoor unit should be no more than that of outdoor unit. Otherwise, it will cause the shortage of cooling (heating) capacity.
- ☆ Install a circuit breaker (or fuse) to each indoor unit according to capacity of the unit and a master circuit breaker to all indoor units. Each of the circuit breaker, which are normally on, is used for short circuit and abnormal overload protection of indoor unit. The master circuit breaker is used to supply or cut off power of all indoor units together. The general power supply of all indoor units must be cut off before cleaning them.
- ☆ In order to start the unit successfully, the general power supply switch of the air-conditioning units should be turned to the “ON” position for 8 hours before running.
- ☆ After each of indoor units received the stop running signal, the fan motor of the indoor unit will use the surplus cool or surplus heat of the heat exchanger go on running for 20-70 seconds, this is the preparation for the next time use and this is the normal phenomenon.
- ☆ When the selected mode of the indoor unit conflict with the mode of outdoor unit, after 5 seconds, the remote control will display the operation conflict, the indoor unit will stop running, then to unify the running modes of the indoor unit and outdoor unit, the unit will get right. There is no conflict in the COOL mode and DRY mode, the FAN mode will not conflict with any other modes.

CONTENTS

1 Safety Information	1
2 The Structure and Components Name of One-way Cassette Type Indoor Unit	2
3 Rated Condition of Air-conditioning Unit.....	2
4 Installation of the One-way Cassette Type Indoor Unit	2
4.1 The requirement for installation space	2
4.2 Selection of the installation location for indoor unit	3
4.3 Dimension of ceiling hatch and location of hoisting screw	3
4.4 Hoisting the main body of the unit	4
4.5 Drainage pipe	4
4.6 Front panel body and installation.....	6
5 Function Description of Functional Dial Switch S7	7
6 Wiring Requirements	7
7 Wired Controller	8
7.1 ON/OFF	8
7.2 TIMER	9
7.3 SLEEP	9
7.4 Swing	10
7.5 FAN.....	10
7.6 Temperature Setting.....	11
7.7 MODE	11
7.8 Error Display	12
8 Troubleshooting	14
8.1 Check the following items before contacting maintenance center.....	14
8.2 They are not malfunction as follow	15
9 Maintenance	16
9.1 Cleaning air filter.....	16
9.2 Installation of the air filter	17
9.3 Closing the front panel.	17
9.4 Cleaning the air inlet grille	17
9.5 Install and change of air purifier(optional).....	17
9.6 Function and usage period for air purifying	18
9.7 Cleaning Outlet vent and Surface Panel.....	18
9.8 Disassembly and installation of guide louver	18
9.9 Maintenance before or after usage season	18

1 Safety Information

Please read this manual carefully before use this unit, and operate it correctly according to the guide in this manual.

Please take specially note to the meaning of these two marks.

 Warning : This mark means that it may cause casualty or badly hurt if the operation is incorrect.

 Note : This mark means that it may cause casualty or property loss if the operation is incorrect.

 Warning!

- Do not adopt fuse with unsuitable capacity or adopt iron thread instead of fuse, otherwise malfunction or fire may happened.
- Turn the main power off immediately if malfunction (such as smell the burning odor etc.) happened.
- Maintain ventilation to prevent oxygen leakage in room.
- Don't insert finger or stick like things into discharge vent or outlet grill.
- Please make sure the unit is installed in the place that can withstand the weight of it adequately. If the place is not strong enough, the air conditioner may drop and cause casualty event.
- Don't spray or smear any oil paint or insecticide on the surface of unit, otherwise, fire may be caused.
- Do not refit the air conditioner. Please contact the agency or professionals to repair or remove the conditioner.

 Note!

- Please check and make sure the cord, drainage pipe and tubes are connected in the correct way to avoid leakage of water and refrigerant, electric shock or fire, etc..
- The main power must be reliably earthed in order to assure the air conditioner is effectively earthed and avoid electric shock. Please don't connect the earthing line with the gas pipe, water pipe, lightning rod or the connecting line of telephone.
- The air conditioner should be started at least after running for 5 min; otherwise it would affect the duration of the unit.
- Don't let the children operate the air conditioner.
- Please don't operate the unit by wet hand.
- Please turn off the main power of the unit before cleaning the conditioner or replace the filter.
- Please turn off the main power if the air conditioner will not be used for a long time.

2 The Structure and Components Name of One-way Cassette Type Indoor Unit

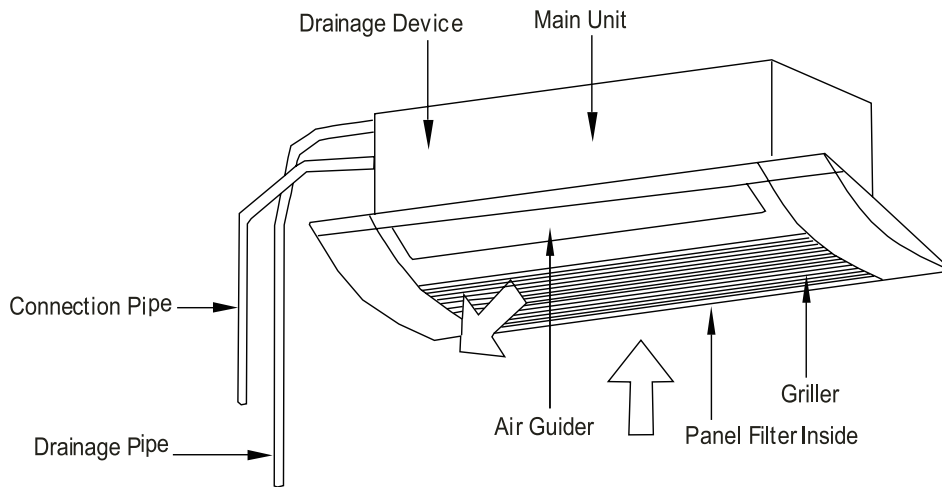

80CO008J24
80CO010J24
80CO013J24

3 Rated Condition of Air-conditioning Unit

	Indoor side state		Outdoor side state	
	Dry bulb temp.°C	Wet bulb temp.°C	Dry bulb temp.°C	Wet bulb temp.°C
Rated cooling	27	19	35	24
Rated heating	20	15	7	6

4 Installation of the One-way Cassette Type Indoor Unit

4.1 The requirement for installation space

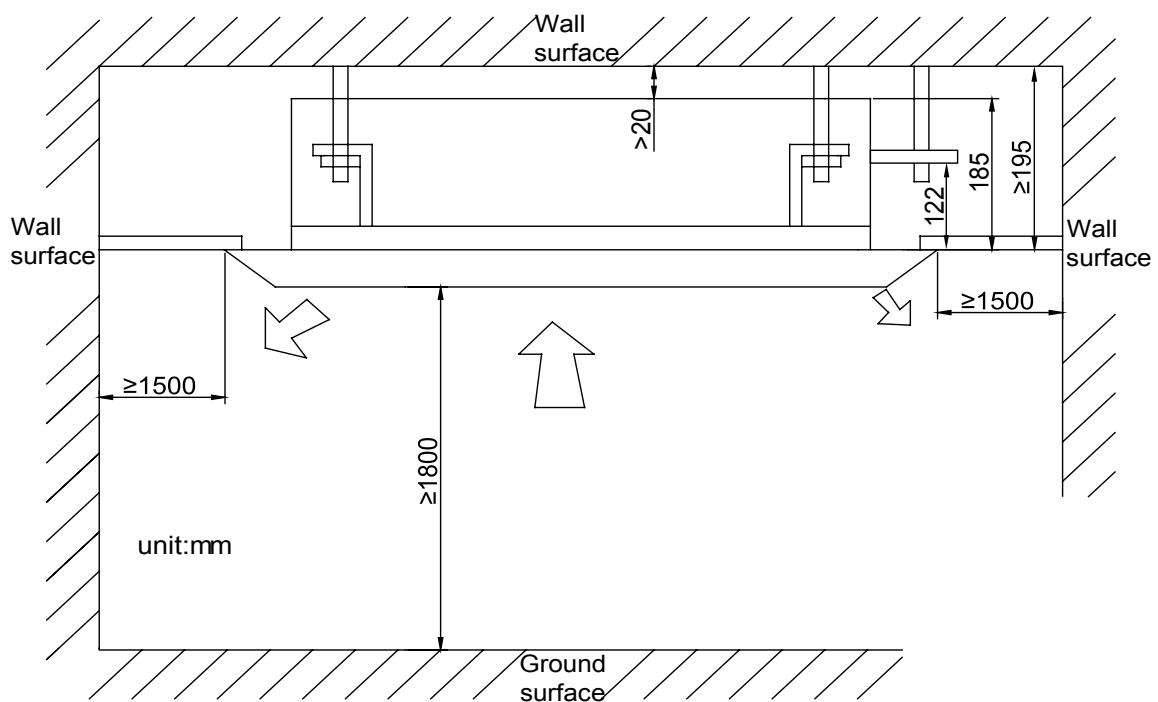

4.2 Selection of the installation location for indoor unit

- Obstruct should be away from the air intake or outlet vent of the indoor unit so that the airflow blow all over the place of the room.
- Make sure the installation of the indoor unit accords with the requirement for installation dimension drawing.
- Select the place which can withstand 4 times weight of the indoor unit and would not increase the operating noise and shake.
- The installation place should be horizontal.
- Select the place, where coagulated water is easy to discharge and outside unit to be connected.
- Above 18000mm between the earth and indoor unit should be ensured for maintenance and repair.
- Use hoisting screw to check if the installation place can withstand 4 times weight of the units and strengthen it before installing.

4.3 Dimension of ceiling hatch and location of hoisting screw

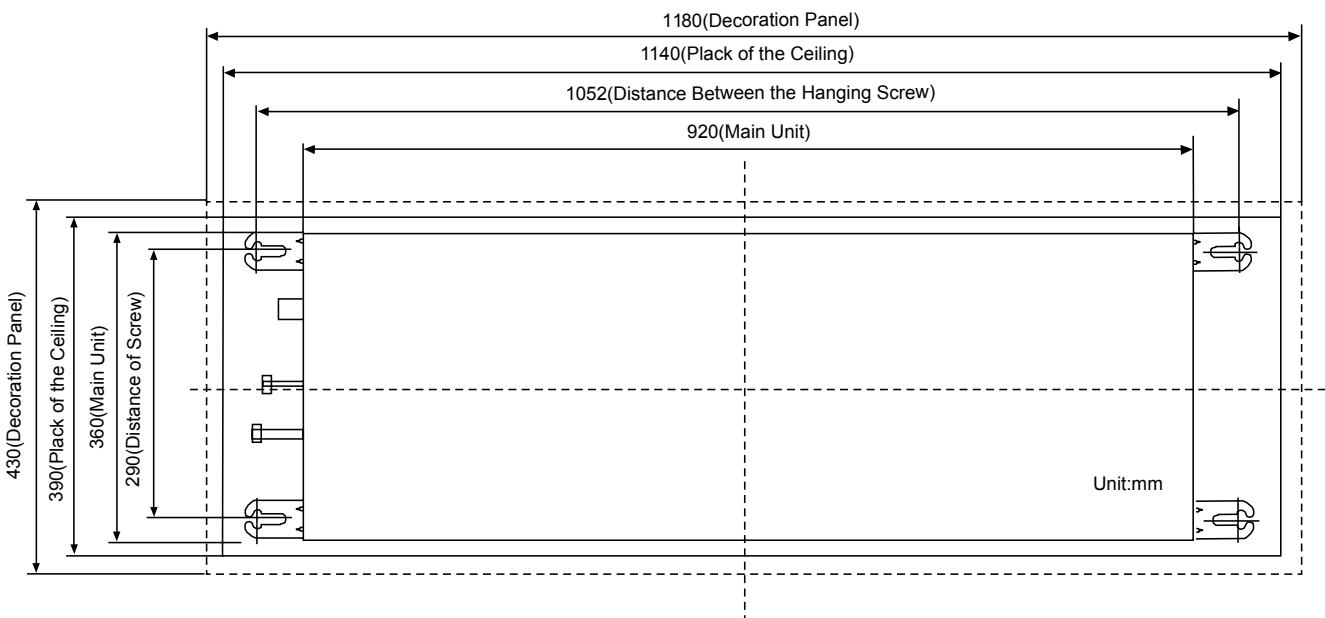

⚠ Important notice:

Drilling the hole of the ceiling and installing the units must be operated by professionals.

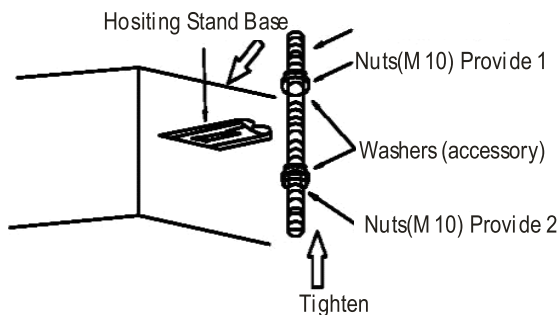

Fig.1

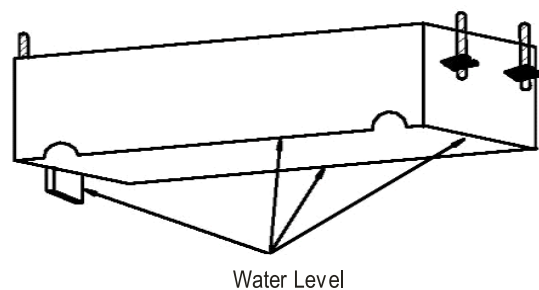

Fig.2

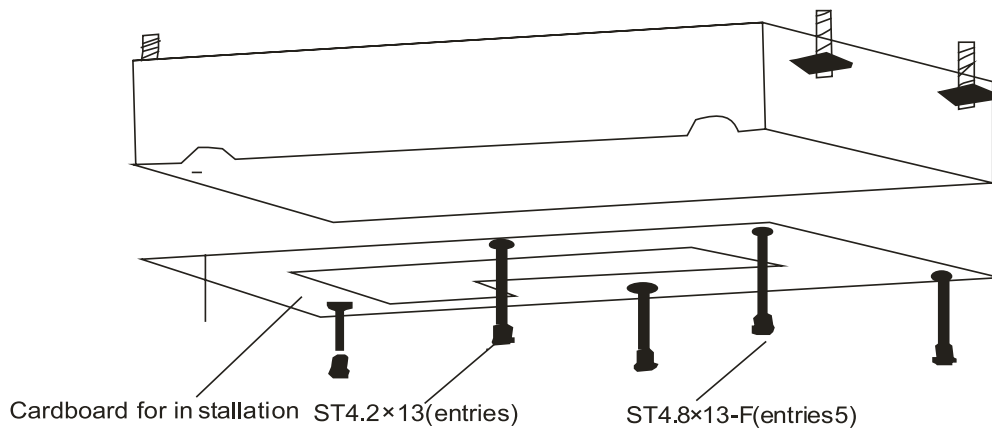

Fig.3

4.4 Hoisting the main body of the unit

1) Hoisting the main body

Attach the hoisting stand base to hoisting screw. In order to firm the hoisting stand base, use nuts with washers on either end of it.(refer to Fig. 1)

2) Please refer to the dimension of ceiling opening on the cardboard for installation

- There is a mark for ceiling opening center on the cardboard.
- There is also a mark for main body center on the cardboard.
- Use screws to fix the installation cardboard on the unit. (refer to Fig.3)

3) Adjust the unit to right installation place.

4) Check if the unit is horizontal.

Inner drainage pump and bobber switch are installed in indoor unit. Check if every side of the unit is horizontal by water lever. (If the unit slants to opposite direction towards which coagulate water flows, it will bring malfunction to the bobber switch and cause water drops. (refer to Fig.2)

5) Unscrew the screws on the cardboard, which can be used for installing front panel.

4.5 Drainage pipe

1) Install the drain hose

- The diameter of the drain hose should be equal or bigger than the connection pipe's. (The diameter of polythene pipe: Outer diameter 25mm Surface thickness $\geq 1.5\text{mm}$)

- Drain hose should be short and drooping gradient should at less 1/100 to prevent the formation of air bubble.

- If drain hose cannot has enough drooping gradient, drain raising pipe should be added.

- To prevent bent of the drain hose, the distance between hoisting stand should is 1 to 1.5m.

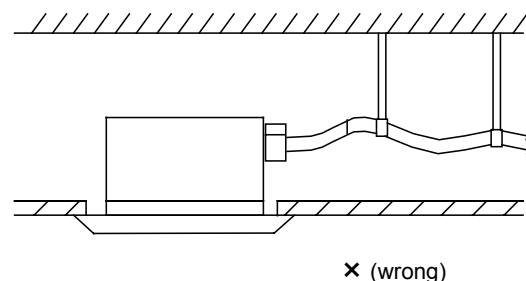
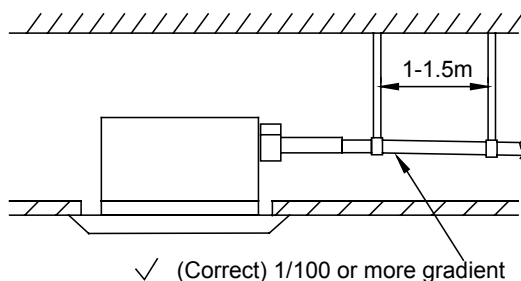

- Use the drain hose and clamp attached. Insert the drain hose to the drain vent, and then tighten the clamp.

- Entwine the big sponge on the clamp of drain hose to insulate heat.

- Heat insulation should be done to indoor drain hose.

2) Drain stepup pipe note

- The install height of the drain raising pipe should less than 280mm.

- The drain raising pipe should form a right angle with the unit, and distance to unit should not be beyond 300mm.

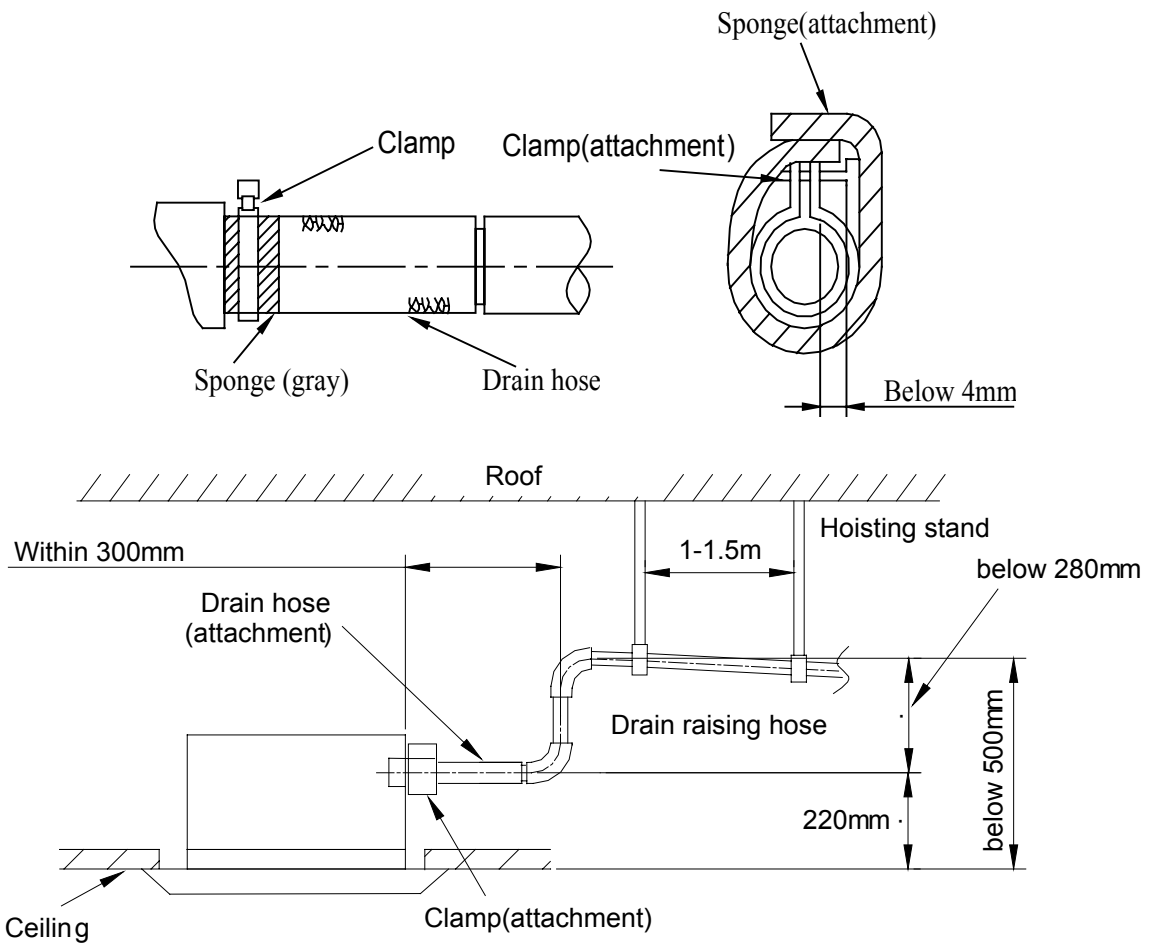

3) Instruction

- The slant gradient of the attached drain hose should be within 75mm so that the drain hole doesn't have to endure the unnecessary outside force.
- Please install the drain hose according to the following process if several drain hoses join together.

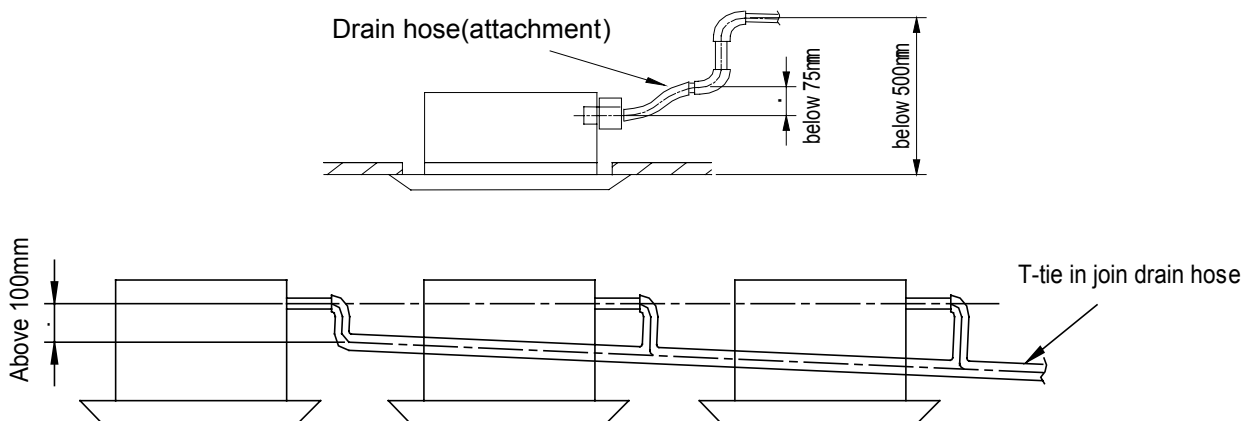

The specs of the selected join drain hose should fit the running capacity of the unit.

4.6 Front panel body and installation

1) Take off the front panel from the panel body.

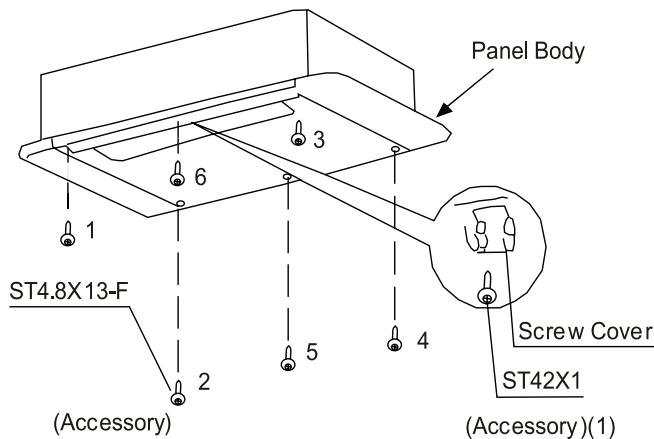

Fig.4

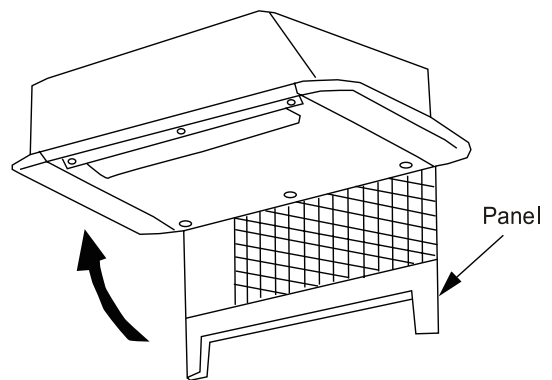

Fig.5

2) AS shown in Fig.4, install the panel body, and then tighten the screws according to the sequences in the figures.

3) As shown in Fig.5, install the panel on the panel ,and then turn it for fastening.

5 Function Description of Functional Dial Switch S7

1) The 3-bit dial switch must be set before energizing the main board and it determines running state of indoor unit.

2) Function of it is as follow:

Dial switch Silk screen	Function	Dial ON	Dial OFF
1(S/R)	Selection of memory mode: A.Selection between reset mode and standby mode after energizing B.This function is available without wired controller.	Standby after energizing	Reset after energizing
2(L/I)	Selection between manual controller and receiver A.If manual controller is selected, remote-control function of receiver will be shielded. B.If receiver is selected, wired controller will be non-effective.	Selecting wired controller	Selecting receiver joint
3(M/S)	Setting of main and slave indoor units A.For resolution of conflict among the modes. B.This function is available without wired controller.	Main indoor unit	Slave indoor unit

6 Wiring Requirements

1) Power Cord Size and Air Switch Capacity

Model	Power Supply	Air Switch Capacity (A)	Minimum Sectional Area of Ground Wire (mm ²)	Minimum Sectional Area of Power Cord (mm ²)
80CO008J24	208-230V ~60Hz	6	1.0	1.0
80CO010J24	208-230V ~60Hz	6	1.0	1.0
80CO013J24	208-230V ~60Hz	6	1.0	1.0

Notes:

①. The size of circuit breaker and power cord in above sheet is selected based on the max power (max current) of unit.

②. Above selection requirements of power cord size: Power cord size is based on multicore copper core cable with operation temperature of 90°C when laying on wire groove at 40°C ambient temperature (IEC 60364-5-523). If the operation condition is different, please calculate according to national standard.

③. Above selection requirements of circuit breaker size: Circuit breaker size is based on ambient temperature of 40°C when the circuit breaker is working. If the operation condition is different, please calculate according to circuit breaker specification.

2) Install circuit breaking device near the unit. The minimum distance between each stage of circuit breaking should be 3mm (The same for both indoor unit and outdoor unit).

7 Wired Controller

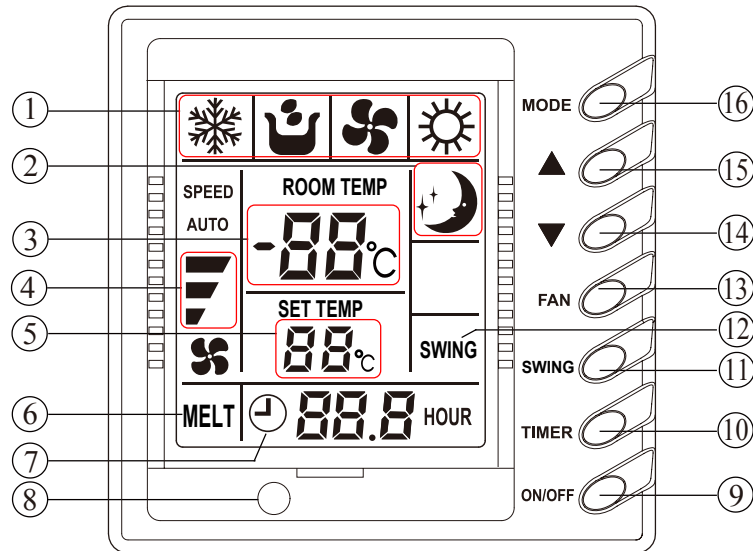

Every part of wired remote controller			
1	Operating mode display (Cool, Dry, Fan, Heat)	9	On/Off button
2	Sleep mode display	10	Timer button
3	Environmental temp.display / Malfunction display	11	Swing button
4	Fan control display (automatic, high, medium, low)	12	Swing display
5	Set Temp. display	13	Fan control button
6	Defrosting display	14	Temp. / Timer reducing button
7	Timer display	15	Temp. / Timer rising button
8	Signal receptor	16	Mode button

7.1 ON/OFF

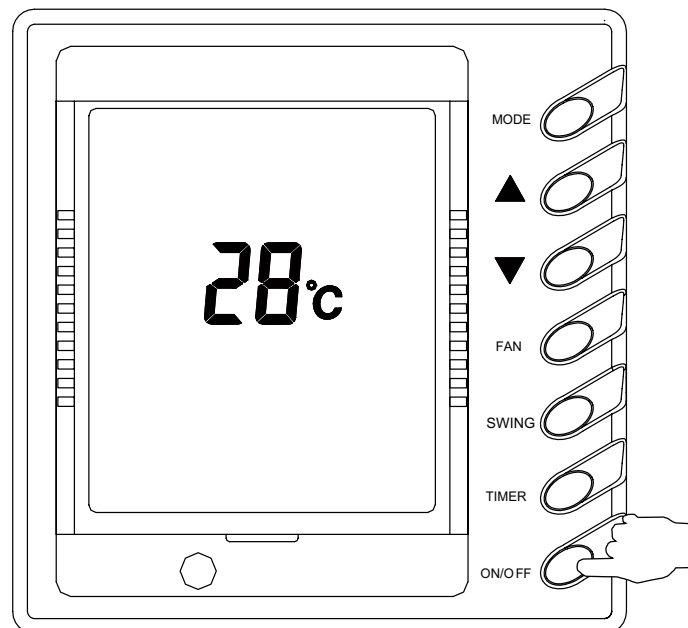

Fig. 7.1

- ① . Press ON/OFF to turn on the unit.
- ② . Press ON/OFF again to stop the unit.
- ⚠ Note: Fig. 7.1 shows the OFF state after power on.

7.2 TIMER

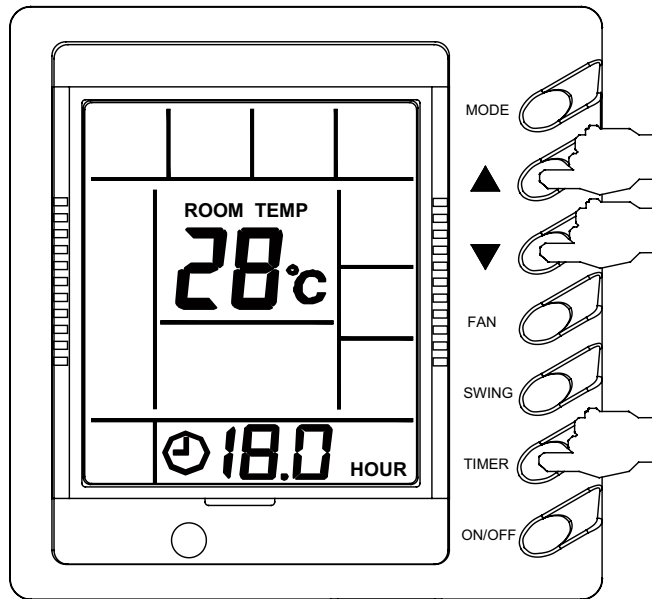

Fig. 7.2

1) Under ON state of the unit, press TIMER to set the OFF time. While under the OFF state of the unit, press TIMER to set the ON time.

2) If there is no timing setting, press TIMER, and then \odot xx.x HOUR will displayed, with \odot and HOUR blinking continuously. Then, press \blacktriangle or \blacktriangledown to adjust the set time. After that, press TIMER to make a confirmation.

3) After power on, press TIMER, and \odot 0.5 HOUR will be displayed, with \odot and HOUR blinking continuously. After that, press TIMER again, and \odot 0.5 HOUR will disappear, which indicates that the timing is canceled. See Fig. 7.2 for the set time.

Timing range: 0.5 hour~24 hours. press \blacktriangle or \blacktriangledown to increase/decrease the set time by 0.5 hour each time. While if press and hold the button continuously, the set time will increase/decrease by 0.5 hour every 0.5 second.

7.3 SLEEP

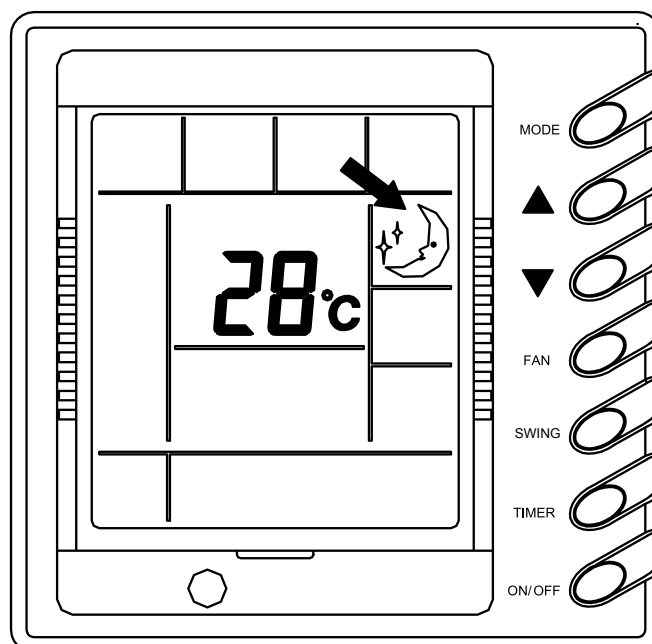

Fig. 7.3

1) In the Cooling or Dry mode, after the unit receives the Sleep command from the wireless controller (for the duct type or ultra-thin duct type indoor unit, the command is transmitted by the wired controller) and runs for one hour, the preset temperature will increase by 1°C and by 1°C after another two hours. After that, the unit will run at this temperature.

2) In the Heating mode, after the unit receives the Sleep command from the wireless controller (for the duct type or ultra-thin duct type indoor unit, the command is transmitted by the wired controller) and runs for one hour, the preset temperature will decrease by 1°C and by 1°C after another two hours. After that, the unit will run at this temperature.

⚠ Note: The Sleep setting is shown as Fig. 7.3 and this function is unavailable in the Dry mode.

7.4 Swing

The swing function will start by pressing “SWING” and stop by another press.

See Fig. 7.4 for how to set the swing function.

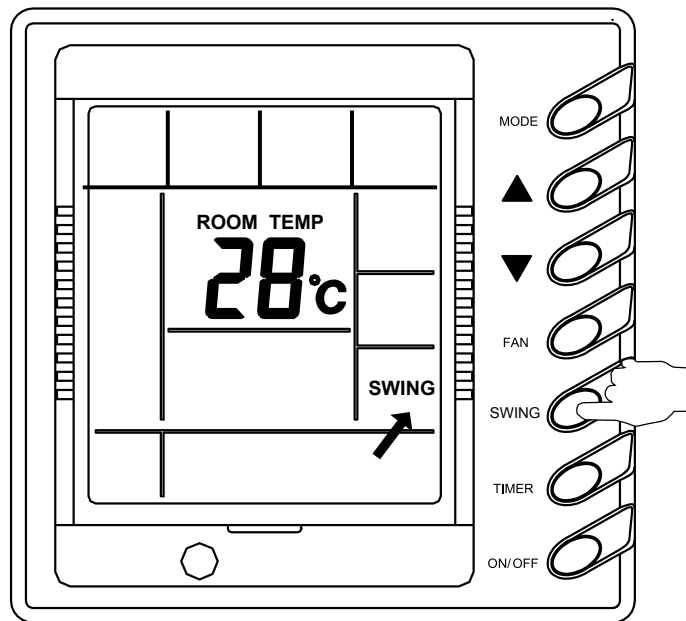

Fig. 7.4

⚠ Note: this function is unavailable for the duct type and ultra-thin duct type indoor unit.

7.5 FAN

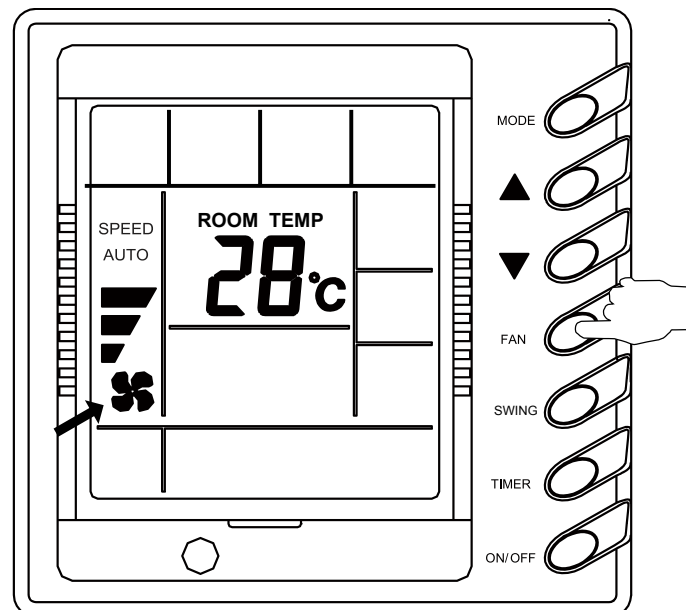
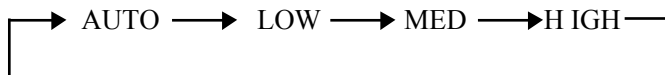

Fig. 7.5

Press Fan to switch the fan speed as the following order circularly.



⚠ Note: In the Dry mode, the fan speed will be set to the LOW speed automatically.

7.6 Temperature Setting

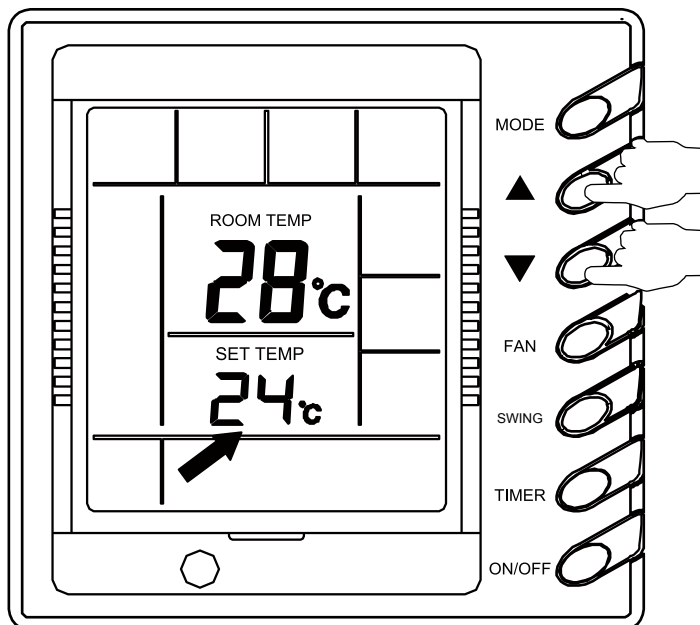

Fig. 7.6

Press ▲ or ▼ to adjust the set temperature and the temperature setting range under each mode is 16°C~30°C. See Fig. 7.6 for the set temperature.

7.7 MODE

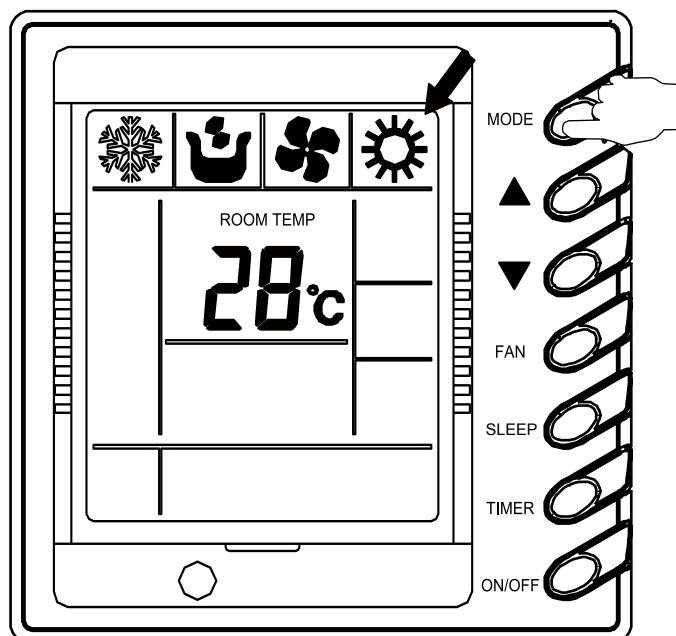
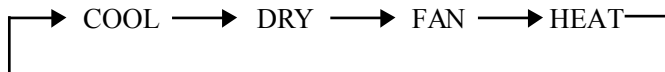

Fig. 7.7

Press MODE to switch the running mode as the following order circularly.



1) In the COOL mode, ❄ will blink. The set temperature should be lower than the room

temperature; otherwise the unit won't run into the COOL mode.

2) In the DRY mode, ☹️ will blink. The fan motor will run at the low speed among a certain temperature range. The dehumidifying effect in this mode is better than that in the COOL mode and the energy saving effect is also better.

3) In the FAN mode, 🌀 will blink.

4) In the HEAT mode, ⚙️ will blink. The set temperature should be higher than the room temperature; Otherwise the unit won't run into the HEAT mode.

7.8 Error Display

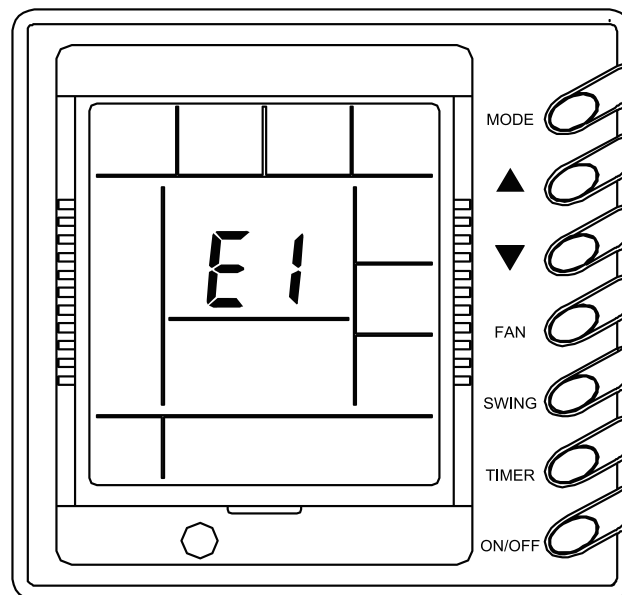

Fig. 7.8

When some error happens, the error code will be shown in the environmental temperature display zone. Fig. 7.8 indicates that the compressor is under high pressure protection.

When some error happens, except the FAN mode under which the unit will still work normally, the outdoor unit and fan will stop under the COOL, DRY and HEAT mode, but the LCD display will not be affected.

When some error is displayed on the controller, please turn off the unit to stop and has it repaired by the specialized personnel.

The meaning of each error code is described

Error Code	Description
E1	High pressure protection of the compressor
E2	Indoor anti-freeze protection
E3	Low pressure protection of the compressor
E4	Discharge temperature protection of the compressor
E5	Compressor overload protection
E6	Communication error
E7	Modes conflict
F0	Indoor environment temperature sensor error
F1	Indoor coil inlet temperature sensor error
F2	Indoor coil mid-way temperature sensor error
F3	Indoor coil outlet temperature sensor error
F4	Outdoor environment temperature sensor error
F5	Outdoor coil inlet temperature sensor error
F6	Outdoor coil mid-way temperature sensor error
F7	Outdoor coil outlet temperature sensor error
F8	Discharge temperature sensor 1 (rated frequency) error
F9	Discharge temperature sensor 2 (digital) error
FA	Oil temperature sensor 1 (rated frequency) error
Fb	Oil temperature sensor 2 (digital) error
Fc	High pressure sensor error
Fd	Low pressure sensor error

8 Troubleshooting

Warning!

- Cut down the main power switch immediately if malfunction (such as smell the burning odor etc.) happened, and then contact service center. If the abnormal state is maintained, the unit may be damaged or electric shock or fire may be happened.
- Do not refit the conditioner. Please contact service center to repair or move the conditioner.

8.1 Check the following items before contacting maintenance center

Phenomena	Reason	Remedial Measures
Air conditioner doesn't run at all	Blow of fuse or breaker	Change fuse or close breaker
	Power cut	Restart when there is power supply
	Don't connect with power	Connect power well
	Low batteries of wireless remote controller	Change new batteries
	Wireless remote controller exceed remote control area	Signal could be received within 8m
Air conditioner runs but stops immediately	Blockage in inlet or outlet vent of indoor or outdoor unit	Clean out blockage
Abnormal cooling or heating	Blockage in inlet or outlet vent of indoor or outdoor unit	Clean out blockage
	Improper of temp. setting	Adjust settings in wireless remote controller
	Low setting of fan speed	Adjust settings in wireless remote controller
	Incorrect of wind direction	Adjust settings in wireless remote controller
	Door or window opened	Close
	Direct sun burn	Hang curtain or jalousie before windows
	Too many people in room	
	Too many heater in room	
Filter blocked by dirt	Clean filter	

 Note: If problem still cannot found out after above checking, please contact service center and instruct phenomena and model.

8.2 They are not malfunction as follow

	Malfunction	Reason
Air conditioner doesn't run	Start up unit immediately after turned off	The overload protects switch makes it run after 3 minutes delay.
	When opening power	Run for about 1 minute without other actions
Mist is blown from air conditioner	When cooling	The high humidity air in room is cooled rapidly
Noise is heard from air conditioner	Slight click sound heard once begin running	Sound of initialization for electric expand valve
	Hissing sound heard continuously when cooling	The sound for gas refrigerant flowing in the unit
	Hissing sound heard when starting or stopping	The sound for gas refrigerant stops flow
	Slight hissing sound heard when running or after running	Sound for running of drainage system
	Creak sound heard when running or after running	The grating sound caused by expands of panel and other parts for the change of temperature
Dust be blown for air conditioner	Started up after long time's doesn't runs	Dust in indoor unit be blown out
Odor gives out from air conditioner	When running	This is because when air conditioning, odors or cigarette smoke from the room that was sucked in is discharged again.

- **After-sales Service**

When having quality or other problems after purchasing air conditioner, please contact the local service center. Refer to the telephone directory.

9 Maintenance

Please cut off the main power supply of the unit when not in use for a long time.

⚠ Warning !

- 1) Do not turn off the unit and cut off the main power supply when cleaning the unit, otherwise the electric shock or harm may happen.
- 2) Don't wash the unit, otherwise the electric shock may happen.

9.1 Cleaning air filter

⚠ Note: Clean the air filter more frequently (about once half a year), when lots of dust around the unit.

- 1) Loosening the clasp.

As shown in Fig. 9.1.1, press the clasp with power by the arrow to loosen the clasp.

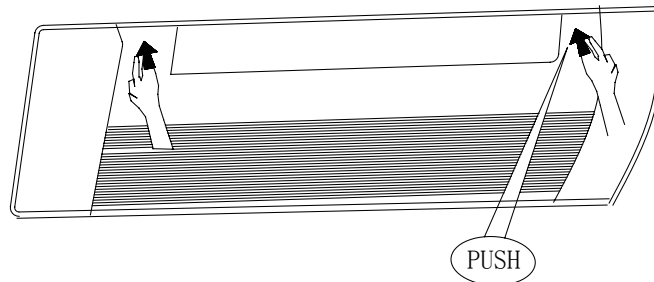

Fig. 9.1.1

- 2) Open the front panel

As shown in Fig. 9.1.2, pull down the panel slowly by the arrow.

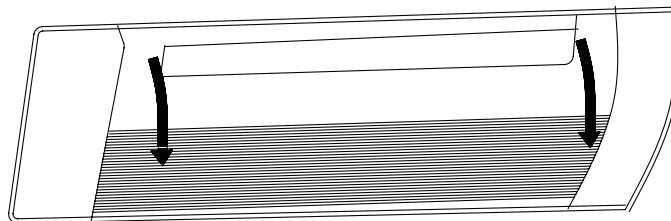

Fig. 9.1.2

- 3) Disassembling the air filter

Buttress the front panel with one hand, and then take out the air filter with the other one. As shown in Fig. 9.1.3.

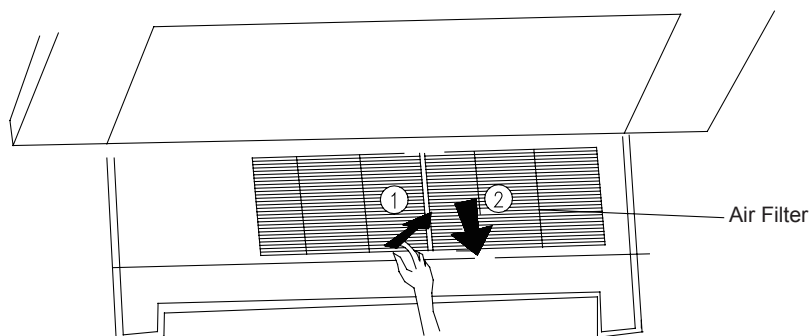

Fig. 9.1.3

- 4) Cleaning the air filter

Either the dust cleaner or the water can be used to clean it. If the filter is too dirty (as oil stain on it), use warm water (lower than 45°C) with neutral scourer to clean, then dry it in the shade.

⚠ Note:

- ①. Never use water above 45°C to wash it to avoid deformation or discoloration.
- ②. Never parch it on the fire or it will be on fire or deform.

9.2 Installation of the air filter

Buttress the front panel with one hand, and then install the air filter with the other one. As shown in Fig. 9.2.

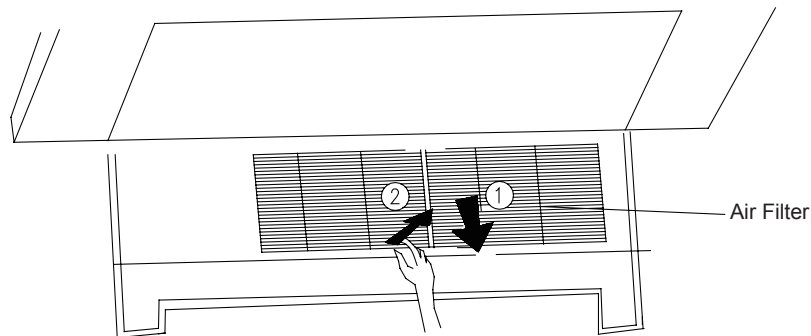

Fig. 9.2

9.3 Closing the front panel.

Close the panel. As shown in Fig. 9.3.

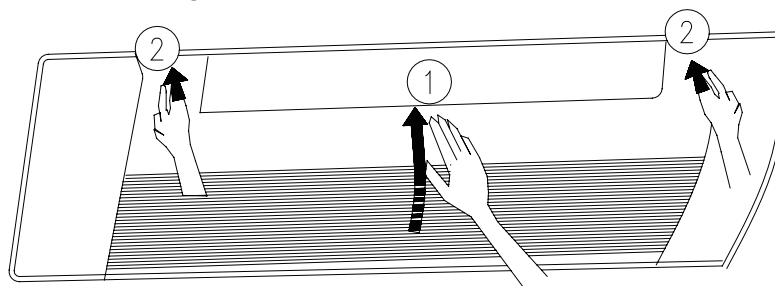

Fig. 9.3

9.4 Cleaning the air inlet grille

- 1) Loosen the clasp (the same as the first point of cleaning the air filter).
- 2) Open the front panel ((the same as the second point of cleaning the air filter).
- 3) Loosen the metal clasp.
- 4) Take out the panel.
- 5) Clean it by pubescence brush, water and neutral cleaning, then throw water or dry it.

⚠ Notice!

- Never use water above 45°C to wash it to avoid deformation or discoloration.
- 6) Locking the metal clasp
 - 7) Close the front panel.(the same as the sixth point in last procedure)

9.5 Install and change of air purifier(optional)

1) Loosen the clasp and open the front panel (the same as the first and second point of cleaning the air filter)

2) Install the purifier

As shown in Fig. 9.5, take out the wrapping bag of purifier filter, then put it into the purifier support, at last fix the purifier support with screws on the bracket.

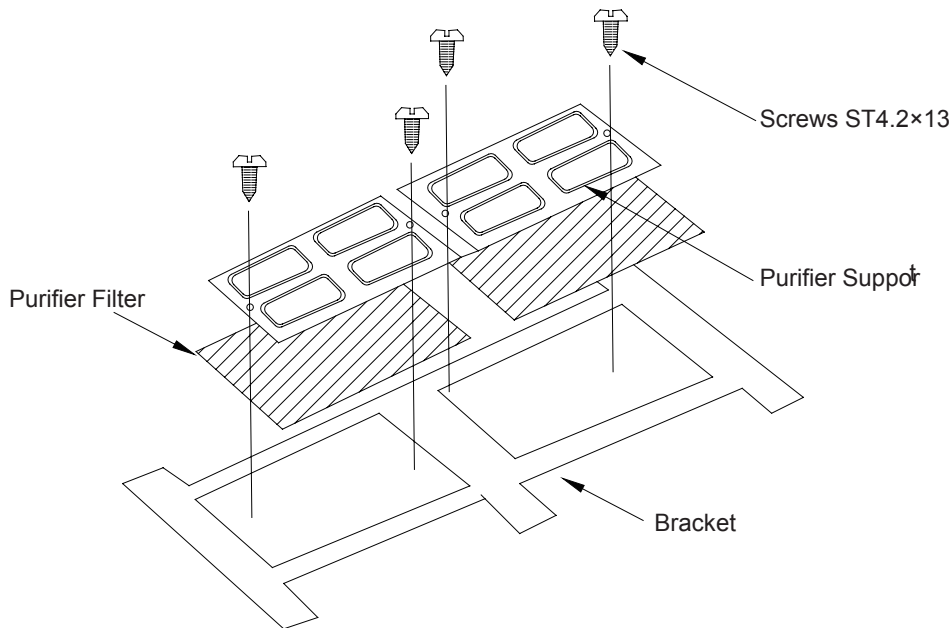

Fig. 9.5

3) Close the panel .(The same as the sixth point in last procedure)

9.6 Function and usage period for air purifying

- Could adsorb CO, CO₂, benzene, aldehyde and odor of gasoline etc..
- Could adsorb deleterious material below 1μm in air, as dust, pollen, bacteria, and virus.
- Usage period is half an year to 1 year. If it is necessary to be changed, purchase new purifier in the nearest DELTA□□ special engaged maintenance center.

9.7 Cleaning Outlet vent and Surface Panel

- Clean the surface panel with soft dry cloth or wet cloth with neutral scourer.
- Never clean surface panel with gasoline, benzene, diluents, cleansing powder etc..
- If the guide louver is too dirty, remove and clean it as follow.

9.8 Disassembly and installation of guide louver

1) Disassembling guide louver.

Screw off the screws at both ends of guide louver.

⚠ Notice!

Do not wipe guide louver powerfully when cleaning, otherwise fluff on surface would fall off.

2) Installing guide louver.

Rotate guide louver slightly and install the protruding edge of both ends into groove on both end of guide louver, and then tighten screws.

9.9 Maintenance before or after usage season

1) Checking before the usage season

- Check if there is blockage in inlet or outlet vent of air conditioner.
- Check if the earthing wire is earthed reliably.
- Check if the air filter had been installed well.
- In order to start up the air conditioner smoothly after stopping for a long time, turn on the main power supply 8 hours before startup of the air conditioner.

2) Maintenance after usage season

- Clean filter and body of air conditioner.
- Cut off the main power supply of air conditioner.

● **Parameters of one-way cassette type indoor unit**

Model	80CO008J24	80CO010J24	80CO013J24
Function	Cooling and heating	Cooling and heating	Cooling and heating
Cooling Capacity (kBtu/h)	7.5	9.6	12.3
Heating Capacity (kBtu/h)	8.5	10.9	13.6
Air Flow Rate (m ³ /h)	450	500	500
Sound Level (dB(A))	45	45	45
Input of Motor (kW)	0.042	0.042	0.042
Power Supply	208-230V/1phase/60Hz		
Anti-electric Shock Protect Type	I		
Dimensions (mm/in) (W×D×H)	Main body: 920 X 360 X 185, 36-1/5"X14-1/5"X7-1/5" Panel: 1180 X 430 X 30, 46-5/8"X16-7/8"X1-1/5"		
Net Weight (kg) (Main body/Panel)	16/3		

- ☆ The above performance parameter is measured according to the standard of GB/T18837-2002, and its cooling or heating capacity and sound level are tested before leaving factory.
- ☆ If the parameters are changed, refer to the data provided on nameplates .

Thank you for Choosing



www.delta-dct.com



66129916169